



ilem
BAKERY



MODULAR OVEN
FOUR MODULAIRE
فرن معياري

**FORNO
MODULARE**

LINEA ELEKTROMECH
FORNO ELETTRICO / ELECTRIC OVEN
FOUR ÉLECTRIQUE/ فرن كهربائي

FCM/1 - FCM/2

FCD/1 - FCD

FCP/1 - FCP

FCS/1 - FCS

FCR/1 - FCR

I La modularità delle camere di cottura, completamente indipendenti, la possibilità di sovrapporne fino ad un massimo di 4 per modello, e la loro finitura completa, sono i punti di forza di questi forni.

Sono adatti per la cottura di prodotti da pasticceria, pane e pizza al taglio o rotonda, in teglia o direttamente sulla piastra del forno.

Temperatura massima di cottura 400°.

- Pannelli esterni in acciaio inox
- Isolamento in lana di roccia sia in pannelli che a fibre lunghe
- Camera di cottura realizzata in lamiera alluminata, illuminazione con lampade alogene. La piastra della camera di cottura, è realizzata in cemento granito, con rete metallica all'interno
- Resistenze elettriche in acciaio inox, corazzate
- Maniglia apertura porta situata sul lato destro del forno, a richiesta si può avere sul lato sinistro. Porta in acciaio inox con vetro di ispezione e tre possibilità di diverse altezze
- Pannello comandi situato lateralmente al forno, nella parte destra, a richiesta è possibile averlo sul lato sinistro o con doppio termostato
- Vaporiera situata nella parte posteriore, di grande potenza per soddisfare qualsiasi tipo di cottura. Il comando di vaporizzazione può essere di tipo manuale od automatico.

OPTIONAL

- Vaporiera supplementare
- Kit vapore automatico con gestione elettronica della percentuale di vapore all'interno della cella
- Cella di lievitazione in acciaio inox e ruote
- Cavalletto di supporto in acciaio inox e ruote
- Supplemento applicazione portateglie in acciaio inox per cavalletto di supporto
- Cappa di aspirazione in acciaio inox
- Maggiorazione Volt 230 trifase
- Piano refrattario
- Aspiratore motorizzato in acciaio inox
- Vaschetta inox ad acqua per condensazione vapori
- Pannello elettronico con:
 - gestione temperatura cielo platea, accensione automatica, timer cottura con avvisatore acustico,
 - economizzatore, 9 programmi memorizzati a cielo platea, accensione automatica, timer cottura con avvisatore acustico,
 - economizzatore, 9 programmi memorizzati

GB The modularity of the completely independent ovens, the possibility of superimposing the ovens (up to a maximum of 4 per model), the complete finish of each oven, are the strengths of these ovens.

They are suitable for baking pastry, bread and pizza cut in squares or the traditional round pizza, in a pan or directly on the oven plate.

Maximum baking temperature 400°.

- External panels in stainless steel
- Thermal Isolation in rock wool both in panels and long fibres
- Oven: made of aluminized sheet, lighting with halogen lamps. The oven plate is made of granite cement, with a metal mesh inside
- Electric heaters in reinforced stainless steel
- The door opening handle is located on the right side of the oven, on request you can have it on the left side. Stainless steel door with inspection glass and three possibilities of different heights
- Electric control panel is located laterally on the oven, on the right side, on request it is possible to have it on the left side or with a double thermostat
- Steamer located in the back, and of sufficient power to satisfy any type of cooking. The steam can be controlled manually or automatically.

OPTIONAL

- Extra steam cooker
- Automatic steam kit with electronic management of the percentage of steam inside the cell
- Stainless steel leavening cell and wheels
- Support stand in stainless steel and wheels
- Stainless steel tray rack application supplement for support stand
- Suction hood in stainless steel
- Increased voltage 230 three-phase
- Heat resistant top
- Motorized stainless-steel extractor
- Stainless steel water tank for vapour condensation
- Electronic panel with:
 - temperature management, automatic ignition, cooking timer with acoustic alarm,
 - economizer, 9 stored programs, automatic start-up, cooking timer with acoustic alarm,
 - economizer, 9 stored programs

F La modularité des chambres de cuisson, complètement indépendantes, la possibilité de superposer les chambres de cuisson (jusqu'à un maximum de 4 par modèle), la finition complète de chaque chambre de cuisson, sont les points de force de ces fours. Ils sont appropriés à la cuisson pour pâtisserie, pain et pizza en tranche ou ronde, en plat à four ou directement sur la plaque du four.

Température maximale de cuisson de 400°.

- Panneaux externes en acier inox
- Isolation en laine de roche tant en panneaux qu'en fibres longues
- Chambre de cuisson réalisée en tôle aluminée, éclairage à lampes halogènes. La plaque de la chambre de cuisson est réalisée en ciment granit, avec une grille métallique à l'intérieur
- Résistances électriques en acier inox, cuirassées
- La poignée de l'ouverture de la porte est située sur le côté droit du four; sur demande il est possible de l'installer sur le côté gauche. Porte en acier inox avec hublot d'inspection et trois possibilités de hauteurs
- Tableau électrique il est positionné latéralement au four, dans la partie droite; sur demande il est possible de l'installer sur le côté gauche ou avec un double thermostat
- Appareil à buée situé dans la partie postérieure, de grande puissance pour satisfaire tout type de cuisson. La commande de vaporisation peut être de type manuel ou automatique.

OPTION

- Appareil à buée supplémentaire
- Kit vapeur automatique avec gestion électronique du pourcentage de vapeur à l'intérieur de la cellule
- Cellule de levage en acier inox et roues
- Chevalet de support en acier inox et roues
- Supplément application porte-plats en acier inox pour chevalet de support
- Hotte d'aspiration en acier inox
- Majoration Volt 230 triphasés
- Plan réfractaire
- Aspirateur motorisé en acier inox
- Bac inox à eau pour condensation des vapeurs
- Panneau électronique avec:
 - gestion de la température voûte / sole, allumage automatique, minuteur cuisson avec signal acoustique,
 - économiseur, 9 programmes mémorisés voûte / sole, allumage automatique, minuteur de cuisson avec signal acoustique,
 - économiseur, 9 programmes mémorisés

SA

إن نمطية الأفران المستقلة تمامًا ، وإمكانية تركيب الأفران (بحد أقصى 4 لكل نموذج) ، والتشطيب الكامل لكل فرن ، هي نقاط قوة هذه الأفران. إنها مناسبة لخبز المعجنات والخبز والبسترا المقطعة في مربعات أو البيتزا التقليدية المستديرة ، في مقلاة أو مباشرة على طبق الفرن. أقصى درجة حرارة للخبز 400 درجة.

- ألواح خارجية من السแตนلس ستيل
- عزل حراري في الصوف الصخري في كل من الألواح والألياف الطويلة
- الفرن: مصنوع من الصاج المنيوم ، الأضاءة بمصابيح هالوجين. صفيحة الفرن مصنوعة من إسمنت الجرانيت ويدخلها شبكة معدنية
- دفايات كهربائية من الاستانلس ستيل المقوى
- يوجد مقبض فتح الباب على الجانب الأيمن من الفرن . وعند الطلب يمكنك وضعه على الجانب الأيسر. باب من الفولاذ المقاوم للصدأ مع زجاج فحص وثلاث احتمالات بارتفاعات مختلفة
- توجد لوحة التحكم الكهربائية بشكل جانبي على الفرن ، على الجانب الأيمن ، وعند الطلب يمكن وضعها على الجانب الأيسر أو مع ترموستات مزدوج
- يوجد قدر بخاري في الخلف وبقوة كافية لإرضاء أي نوع من أنواع الطهي. يمكن التحكم في البخار يدويا أو تلقائيا.

خيارات

- قدر بخار إضافي
- مجموعة البخار الأوتوماتيكي مع إدارة إلكترونية لنسبة البخار داخل الخلية
- خلية تخمير وعجلات من الفولاذ المقاوم للصدأ
- حامل دعم من الفولاذ المقاوم للصدأ وعجلات
- ملحق تطبيق رف صينية من الفولاذ المقاوم للصدأ لحامل الدعم
- شفاط من الفولاذ المقاوم للصدأ
- زيادة الجهد 230 ثلاث مراحل
- قمة مقاومة للحرارة
- مستخرج ميكانيكي من الفولاذ المقاوم للصدأ
- خزان مياه من الفولاذ المقاوم للصدأ لتكثيف البخار
- لوحة إلكترونية مع:
 - إدارة درجة الحرارة ، الإشعال التلقائي ، مؤقت الطبخ مع التنبيه الصوتي ،
 - اقتصادي ، 9 برامج مخزنة ، بدء تشغيل تلقائي ، مؤقت للطهي مع إنذار صوتي ،
 - المقتصد ، 9 برامج مخزنة

FCM/1 - FCM/2

FCD/1 - FCD

FCP/1 - FCP



MODELLO MODEL MODÈLE النوع	N° CAMERE CHAMBRES غرف	DIMENSIONI CAMERE CHAMBERS SIZE DIMENSIONS CHAMBRES حجم الغرفة	DIMENSIONI ESTERNE OVERALL SIZE DIMENSIONS EXTÉRIEURES الأبعاد الخارجية	MASSA WEIGHT POIDS كتلة	N° TEGLIE TRAY PLATEAUX صينية	N° PIZZE Ø 30 CM	DIMENSIONI TEGLIE TRAY SIZES TAILLE DES PLATEAUX أحجام الصواني	POTENZA POWER PUISSANCE قوة كو	POTENZA VAPORIERE STEAM POWER PUISSANCE DE VAPEUR قوة باخرة	ALIMENTAZIONE CURRENT COURANTE تيار
		L X P X H = mm	L X P X H = mm	Kg		mm	KW		V	
FCM/1	1	500 x 500 x 120	720 x 640 x 370	42	1	-	500 x 500	3	-	230M 400+N
FCM/2	2	500 x 500 x 120 + 120	720 x 640 x 540	62	2	-	500 x 500	4,5	-	230M 400+N

MODELLO MODEL MODÈLE النوع	N° CAMERE CHAMBRES غرف	DIMENSIONI CAMERE CHAMBERS SIZE DIMENSIONS CHAMBRES حجم الغرفة	DIMENSIONI ESTERNE OVERALL SIZE DIMENSIONS EXTÉRIEURES الأبعاد الخارجية	MASSA WEIGHT POIDS كتلة	N° TEGLIE TRAY PLATEAUX صينية	N° PIZZE Ø 30 CM	DIMENSIONI TEGLIE TRAY SIZES TAILLE DES PLATEAUX أحجام الصواني	POTENZA POWER PUISSANCE قوة كو	POTENZA VAPORIERE STEAM POWER PUISSANCE DE VAPEUR قوة باخرة	ALIMENTAZIONE CURRENT COURANTE تيار
		L X P X H = mm	L X P X H = mm	Kg		mm	KW	KW	V	
FCD/1	1	620 x 900 x 180	920 x 1100 x 420	120		6		6	1,5	230T 400+N
FCD	2	620 x 900 x 180 + 180	925 x 1100 x 760	195	4	6 + 6	600 x 400	12	-	230T 400+N

CELLA DI LIEVITAZIONE LEAVENING CELL CELLULE DE LEVAGE خلية التخمر				60	16	6 + 6	600 x 400	1,6		230M
---	--	--	--	----	----	-------	-----------	-----	--	------

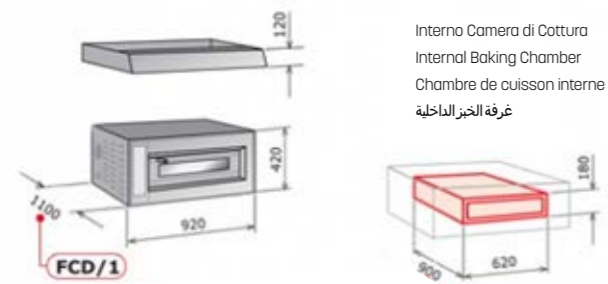

Interno Camera di Cottura
Internal Baking Chamber
Chambre de cuisson interne
غرفة الخبز الداخلية

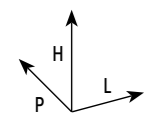
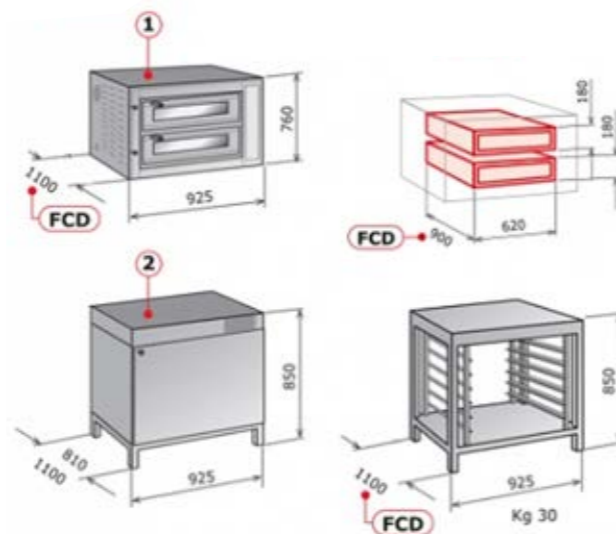

Dimensioni, specifiche tecniche, illustrazioni e descrizioni possono subire variazioni SENZA preavviso. / Dimensions, technical specifications, illustrations and descriptions CAN undergo variations without notice. / Les dimensions, les spécifications techniques, les illustrations et les descriptions sont sujets à changement SANS preavis. / الأبعاد والمواصفات الفنية والرسوم التوضيحية والأوصاف عرضة للتغيير دون إشعار /



MODELLO MODEL MODÈLE النوع	N° CAMERE CHAMBRES غرف	DIMENSIONI CAMERE CHAMBERS SIZE DIMENSIONS CHAMBRES حجم الغرفة	DIMENSIONI ESTERNE OVERALL SIZE DIMENSIONS EXTÉRIEURES الأبعاد الخارجية	MASSA WEIGHT POIDS كتلة	N° TEGLIE TRAY PLATEAUX صينية	N° PIZZE Ø 30 CM	DIMENSIONI TEGLIE TRAY SIZES TAILLE DES PLATEAUX أحجام الصواني	POTENZA POWER PUISSANCE قوة كو	POTENZA VAPORIERE STEAM POWER PUISSANCE DE VAPEUR قوة باخرة	ALIMENTAZIONE CURRENT COURANTE تيار
		L X P X H = mm	L X P X H = mm	Kg		mm	KW	KW	V	
FCP/1	1	1020 x 700 x 160	1320 x 900 x 400	130	2	6	600 x 400	8,7	-	230T 400+N
FCP	2	1020 x 700 x 160 + 160	1320 x 900 x 750	250	4	6 + 6	600 x 400	17,4	-	230T 400+N

CELLA DI LIEVITAZIONE LEAVENING CELL CELLULE DE LEVAGE خلية التخمر				60	10	6 + 6	600 x 400	1,6		230M
---	--	--	--	----	----	-------	-----------	-----	--	------

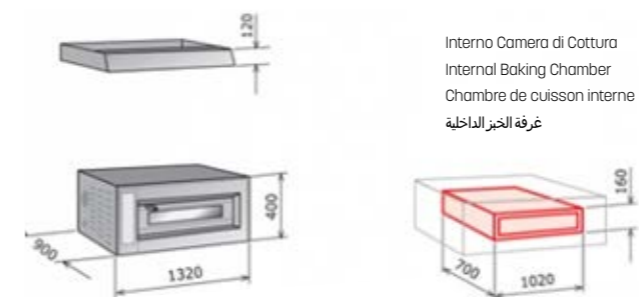

Interno Camera di Cottura
Internal Baking Chamber
Chambre de cuisson interne
غرفة الخبز الداخلية

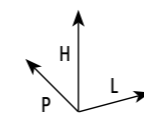
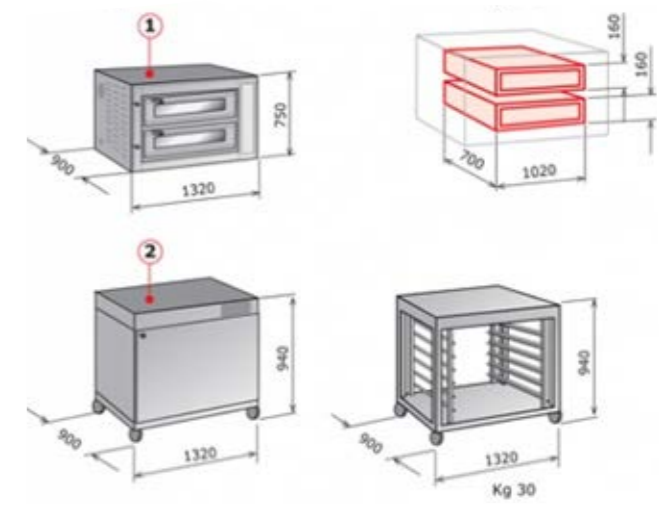

Dimensioni, specifiche tecniche, illustrazioni e descrizioni possono subire variazioni SENZA preavviso. / Dimensions, technical specifications, illustrations and descriptions CAN undergo variations without notice. / Les dimensions, les spécifications techniques, les illustrations et les descriptions sont sujets à changement SANS preavis. / الأبعاد والمواصفات الفنية والرسوم التوضيحية والأوصاف عرضة للتغيير دون إشعار /

FCS/1 - FCS

MODELLO MODEL MODÈLE النوع	N° CAMERE CHAMBRES غرف	DIMENSIONI CAMERE CHAMBERS SIZE DIMENSIONS CHAMBRES حجم الغرفة	DIMENSIONI ESTERNE OVERALL SIZE DIMENSIONS EXTÉRIEURES الأبعاد الخارجية	MASSA WEIGHT POIDS كتلة	N° TEGLIE TRAY PLATEAUX صينية	N° PIZZE Ø 30 CM	DIMENSIONI TEGLIE TRAY SIZES TAILLE DES PLATEAUX أحجام الصواني	POTENZA POWER PUISSANCE قوة كو	POTENZA VAPORIERE STEAM POWER PUISSANCE DE VAPEUR قوة باخرة	ALIMENTAZIONE CURRENT COURANTE تيار
		L X P X H = mm	L X P X H = mm	Kg			mm	KW	KW	V
FCS/1	1	1020 x 1020 x 160	1320 x 1220 x 400	170	4	9	600 x 400	10,5	-	230T 400+T
FCS	2	1020 x 1020 x 160 + 160	1320 x 1220 x 750	300	8	9 + 9	600 x 400	21	-	230T 400+N
CELLA DI LIEVITAZIONE LEAVENING CELL CELLULE DE LEVAGE خلية التخمر				60	10	-	600 x 400	1,6		230M

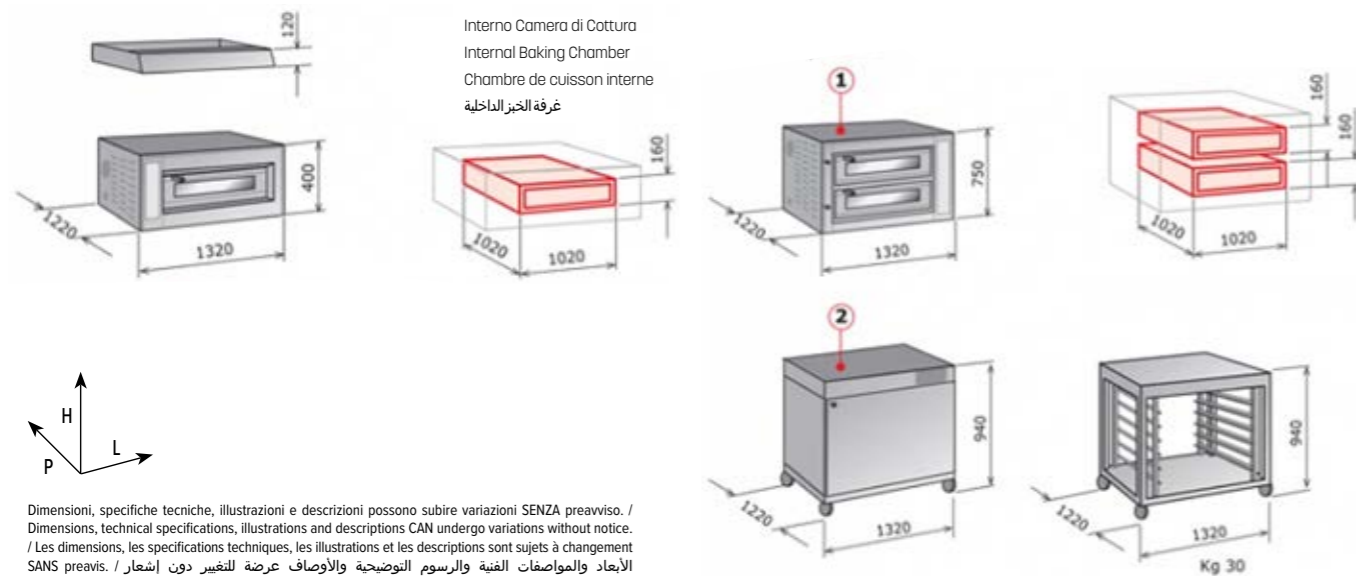

FCR/1 - FCR

MODELLO MODEL MODÈLE النوع	N° CAMERE CHAMBRES غرف	DIMENSIONI CAMERE CHAMBERS SIZE DIMENSIONS CHAMBRES حجم الغرفة	DIMENSIONI ESTERNE OVERALL SIZE DIMENSIONS EXTÉRIEURES الأبعاد الخارجية	MASSA WEIGHT POIDS كتلة	N° TEGLIE TRAY PLATEAUX صينية	N° PIZZE Ø 30 CM	DIMENSIONI TEGLIE TRAY SIZES TAILLE DES PLATEAUX أحجام الصواني	POTENZA POWER PUISSANCE قوة كو	POTENZA VAPORIERE STEAM POWER PUISSANCE DE VAPEUR قوة باخرة	ALIMENTAZIONE CURRENT COURANTE تيار
		L X P X H = mm	L X P X H = mm	Kg			mm	KW	KW	V
FCR/1	1	620 x 650 x 180	920 x 860 x 420	90	-	-	-	4,8	1,5	230T 400+N
FCR	2	620 x 650 x 180 + 180	925 x 860 x 760	155	2	4 + 4	600 x 600	9,6	-	230T 400+N
CELLA DI LIEVITAZIONE LEAVENING CELL CELLULE DE LEVAGE خلية التخمر				80	16	6 + 6	600 x 400	1,6		230M

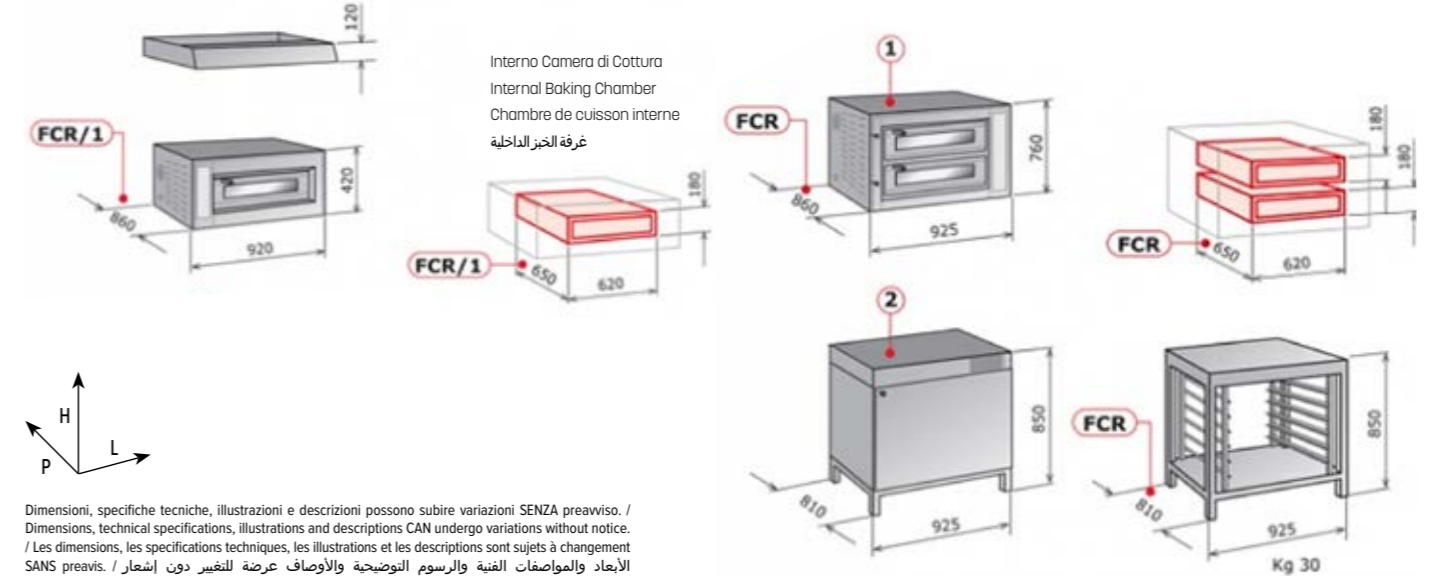

LINEA DIGITAL
FORNO ELETTRICO / ELECTRIC OVEN
FOUR ÉLECTRIQUE/ فرن كهربائي

RAPIDO 1

MD

MD/C

MD/S

MD/CO

MD/CT

MD/CP/1

CPS/1

MD/CN/R

RAPIDO 2 CPR BICAMERA

MD/CN

MD/CS

SUPER RAPIDO CPD BICAMERA

MD/CP BICAMERA

CPS BICAMERA

MD/CH



L La linea Digital, oltre alle caratteristiche di serie descritte per la linea Elektromech, prevede:

- Guarnizioni della porta flessibili in acciaio inox
- Due maniglie di apertura porta, una a sinistra e una a destra ad eccezione del modello MD che ha una sola maniglia. Porta in acciaio inox con vetro di ispezione e tre possibilità di diverse altezze cm 18/25/30.

OPTIONAL

- Cella di lievitazione
- Cavalletto di supporto
- Cappa aspirazione
- Maggiorazione 230 Volt trifase
- Valvola doppio termostato
- Cella di lievitazione (2MD / CO = h88 3MD / CO = h58)
- Cavalletto di supporto (2MD / CO = h90 3MD / CO = h60)
- Valvola e scheda digitale per economizzatore
- Supplemento applicazione portateglie in acciaio inox per cavalletto di supporto
- Applicazione scheda digitale con parzializzatore di consumo dotato di accensione automatica del forno; regolazione indipendente e differenziata (cielo e platea) della potenza con riduzione fino al 50% della potenza impiegata; tempo di cottura programmabile
- Porta a vetro con apertura verso l'alto
- Applicazione vaporiera per modulare
- Kit vaschetta condensazione vapori
- Aspiratore inox
- Maggiorazione bocca h. cm 30
- Kit vapore automatico in cella
- Kit ruote
- Carrello estraibile in cella di lievitazione MD / CO / S-MD / CN
- Carrello estraibile in cella di lievitazione MD / CO - MD / CO / S - MD / CN - MD / CS
- Vaporiera maggiorata MD / CO - MD / CO / S - MD / CN - MD / CS
- Resistenze maggiorate per pizza
- Vaporiera
- Tappeto di infornamento
- Cappa con aspiratore
- Cavalletto
- App Cloud EPoCA per connettere in remoto il forno tramite Wi-Fi

GB The Digital line, in addition to the standard features described for the Elektromech line, includes:

- Flexible stainless-steel door seals
- Two door opening handles, one on the left and one on the right except for the MD model which has only one handle. Stainless steel door with inspection glass and three possibilities of different heights cm 18/25/30.

OPTIONAL

- Leavening cell
- Support stand
- Extractor hood
- Increase Voltage 230 three-phase
- Valve and double thermostat
- Leavening cell (2MD / CO = h88 3MD / CO = h58)
- Support stand (2MD / CO = h90 3MD / CO = h60)
- Valve and digital card with economiser
- Stainless steel tray rack application supplement for support stand
- Digital card application with consumption divider equipped with automatic ignition of the oven; independent and differentiated regulation (top and bottom) of the power with reduction of up to 50% of the power used; programmable cooking time
- Glass door with upward opening
- Steam generator application for module
- Steam condensation tray kit
- Stainless steel extractor
- Increase in the mouth h. cm 30
- Automatic steam kit in the cell
- Wheels kit
- Pull-out trolley in leavening chamber MD/CO - MD/C
- Pull-out trolley in leavening chamber MD / CO / S-MD / CN
- Increased steamer MD / CO - MD / CO / S - MD / CN - MD / CS
- Increased resistance for pizza
- Steamer
- Baking mat
- Extractor hood
- Stand
- EPoCA Cloud App to remotely connect the oven via Wi-Fi

F La ligne Digital, en plus des fonctionnalités standard décrites pour la ligne Elektromech, comprend :

- Garnitures de porte flexibles en acier inox
- Deux poignées d'ouverture de la porte, une à gauche et une à droite, sauf le modèle MD qui possède une seule poignée. Porte en acier inox avec hublot d'inspection et trois possibilités de hauteurs cm 18/25/30.

OPTIONS

- Cellule de levage
- Chevalet de support
- Hotte aspirante
- Majoration Volt 230 triphasés
- Vanne et double thermostat
- Cellule de levage (2MD/CO=h88 3MD/CO=h58)
- Chevalet de support (2MD/CO=h90 3MD/CO=h60)
- Vanne et fiche numérique avec économiseur
- Supplément application porte-plats en acier inox pour chevalet de support
- Application à carte numérique avec diviseur de consommation équipé d'un allumage automatique du four ; régulation indépendante et différenciée (haut et bas) de la puissance avec réduction jusqu'à 50% de la puissance utilisée ; temps de cuisson programmable
- Application appareil à buée pour module
- Kit bac de condensation des vapeurs
- Aspirateur inox
- Majoration bouche h. cm 30
- Kit vapeur automatique en cellule
- Kit roues
- Chariot extractible en cellule de levage MD / CO / S-MD / CN
- Chariot extractible en cellule de levage MD / CO - MD / CO / S - MD / CN - MD / CS
- Appareil à buée majoré MD / CO - MD / CO / S - MD / CN - MD / CS
- Résistances majorées pour pizzas
- Appareil à buée
- Tapis d'enfournement
- Hotte avec aspirateur
- Chevalet
- Application EPoCA Cloud pour connecter le four à distance via Wi-Fi

SA يتضمن خط Digital ، بالإضافة إلى الميزات القياسية الموضحة لخط Elektromech ، ما يلي:

- أختام أبواب مرنة من الفولاذ المقاوم للصدأ
- مقبضان لفتح الباب ، أحدهما على اليسار والآخر على اليمين باستثناء موديل MD الذي يحتوي على مقبض واحد فقط. باب ستانلس ستيل مع زجاج فحص وثلاث احتمالات بارتفاعات مختلفة سم 18/25/30.

خيارات

- خلية التخمير
- وقفة دعم
- غطاء الشفاط
- زيادة الجهد 230 ثلاث مراحل
- صمام وترموستات مزدوج
- خلية التخمير (2MD / CO = h88 3MD / CO = h58)
- حامل الدعم (2MD / CO = h90 3MD / CO = h60)
- صمام وبطاقة رقمية مع اقتصادي
- ملحق تطبيق رف صينية من الفولاذ المقاوم للصدأ لحامل الدعم
- تطبيق البطاقة الرقمية مع مقسم استهلاك مجهز بإشعال أوتوماتيكي للفرن ؛ تنظيم مستقل ومتباين (علوي وسفلي) للطاقة مع تقليل يصل إلى 50٪ من الطاقة المستخدمة ؛ وقت الطهي القابل للبرمجة
- باب زجاجي يفتح لأعلى
- تطبيق مولد البخار للوحدة النمطية
- طقم صينية تكثيف البخار
- مستخرج من الستانلس ستيل
- زيادة في الفم ح. سم 30
- طقم بخار أوتوماتيكي في الخلية
- طقم عجلات
- عربة تسحب للخارج في حجرة التخمير MD / CO - MD / C
- عربة قابلة للسحب في غرفة التخمير MD / CO / S-MD / CN
- زيادة القدر البخاري MD / CO - MD / CO / S - MD / CN - MD / CS
- مقاومة متزايدة للبيترتا
- باخرة
- حصيرة الخبز
- غطاء الشفاط
- يقف
- تطبيق EPoCA Cloud لتوصيل الفرن عن بعد عبر Wi-Fi

RAPIDO 1

MD

MD/C

MD/S

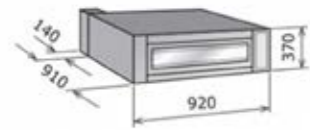

MODELLO MODEL MODÈLE النوع	N° CAMERE CHAMBERS CHAMBRES غرف	DIMENSIONI CAMERE CHAMBERS SIZE DIMENSIONS CHAMBRES حجم الغرفة	DIMENSIONI ESTERNE OVERALL SIZE DIMENSIONS EXTÉRIEURES الأبعاد الخارجية	MASSA WEIGHT POIDS كتلة	N° TEGLIE TRAY PLATEAUX صينية	N° PIZZE Ø 30 CM	DIMENSIONI TEGLIE TRAY SIZES TAILLE DES PLATEAUX أحجام الصواني	POTENZA POWER PUISSANCE قوة كو	PARZIALIZZATORE POWER DIVIDER PARTIALISATEUR مقسم الطاقة	ALIMENTAZIONE CURRENT COURANTE تيار
		L X P X H = mm	L X P X H = mm	Kg			mm	KW	KW	V
RAPIDO 1	1	620 x 650 x 180	920 x 910 + 140 x 370	100	1	4	600 x 600	4,6	-	400+N

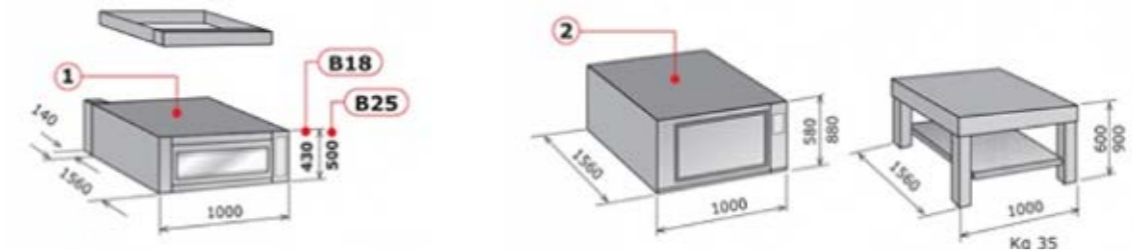

MODELLO MODEL MODÈLE النوع	N° CAMERE CHAMBERS CHAMBRES غرف	DIMENSIONI CAMERE CHAMBERS SIZE DIMENSIONS CHAMBRES حجم الغرفة	DIMENSIONI ESTERNE OVERALL SIZE DIMENSIONS EXTÉRIEURES الأبعاد الخارجية	MASSA WEIGHT POIDS كتلة	N° TEGLIE TRAY PLATEAUX صينية	N° PIZZE Ø 30 CM	DIMENSIONI TEGLIE TRAY SIZES TAILLE DES PLATEAUX أحجام الصواني	POTENZA POWER PUISSANCE قوة كو	PARZIALIZZATORE POWER DIVIDER PARTIALISATEUR مقسم الطاقة	ALIMENTAZIONE CURRENT COURANTE تيار
		L X P X H = mm	L X P X H = mm	Kg			mm	KW	KW	V
MD/C-B18	1	620 x 1300 x 180	1000 x 1560 + 140 x 430	220	3	6	600 x 400	8	4	400+N
MD/C-B25	1	620 x 1300 x 250	1000 x 1560 + 140 x 500	220	3	6	600 x 400	8	4	400+N
CELLA DI LIEVITAZIONE LEAVENING CELL CELLULE DE LEVAGE خلية التخمر	-	-	1000 x 1560 x 580-880	120	15-24	-	600 x 400	1,6	-	230M

MODELLO MODEL MODÈLE النوع	N° CAMERE CHAMBERS CHAMBRES غرف	DIMENSIONI CAMERE CHAMBERS SIZE DIMENSIONS CHAMBRES حجم الغرفة	DIMENSIONI ESTERNE OVERALL SIZE DIMENSIONS EXTÉRIEURES الأبعاد الخارجية	MASSA WEIGHT POIDS كتلة	N° TEGLIE TRAY PLATEAUX صينية	N° PIZZE Ø 30 CM	DIMENSIONI TEGLIE TRAY SIZES TAILLE DES PLATEAUX أحجام الصواني	POTENZA POWER PUISSANCE قوة كو	PARZIALIZZATORE POWER DIVIDER PARTIALISATEUR مقسم الطاقة	ALIMENTAZIONE CURRENT COURANTE تيار
		L X P X H = mm	L X P X H = mm	Kg			mm	KW	KW	V
MD-B18	1	620 x 900 x 180	1000 x 1160 + 140 x 430	150	2	4	600 x 400	6	3	400+N
MD-B25	1	620 x 900 x 250	1000 x 1160 + 140 x 500	150	2	4	600 x 400	6	3	400+N
CELLA DI LIEVITAZIONE LEAVENING CELL CELLULE DE LEVAGE خلية التخمر	-	-	1000 x 1160 x 580-880	80	10-16	-	600 x 400	1,6	-	230M

MODELLO MODEL MODÈLE النوع	N° CAMERE CHAMBERS CHAMBRES غرف	DIMENSIONI CAMERE CHAMBERS SIZE DIMENSIONS CHAMBRES حجم الغرفة	DIMENSIONI ESTERNE OVERALL SIZE DIMENSIONS EXTÉRIEURES الأبعاد الخارجية	MASSA WEIGHT POIDS كتلة	N° TEGLIE TRAY PLATEAUX صينية	N° PIZZE Ø 30 CM	DIMENSIONI TEGLIE TRAY SIZES TAILLE DES PLATEAUX أحجام الصواني	POTENZA POWER PUISSANCE قوة كو	PARZIALIZZATORE POWER DIVIDER PARTIALISATEUR مقسم الطاقة	ALIMENTAZIONE CURRENT COURANTE تيار
		L X P X H = mm	L X P X H = mm	Kg			mm	KW	KW	V
MD/S-B18	1	820 x 700 x 180	1200 x 960 + 140 x 430	180	2	4	600 x 400	6,6	3,3	400+N
MD/S-B25	1	820 x 700 x 250	1200 x 960 + 140 x 500	180	2	4	600 x 400	6,6	3,3	400+N
CELLA DI LIEVITAZIONE LEAVENING CELL CELLULE DE LEVAGE خلية التخمر	-	-	1200 x 960 x 580-880	85	10-16	-	600 x 400	1,6	-	230M

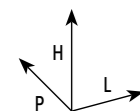
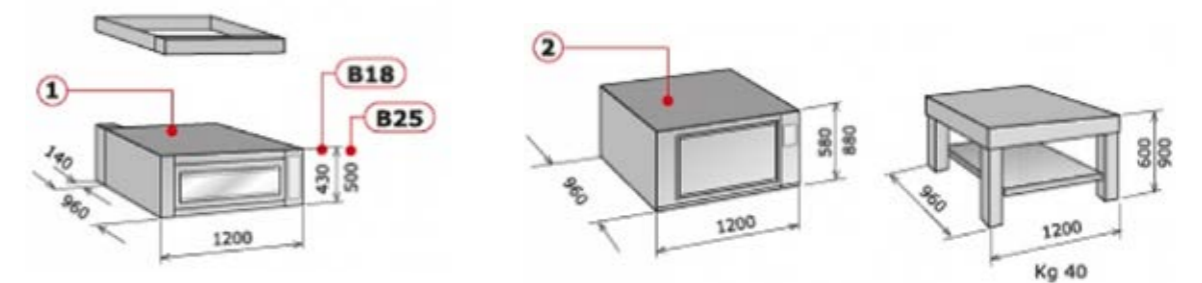
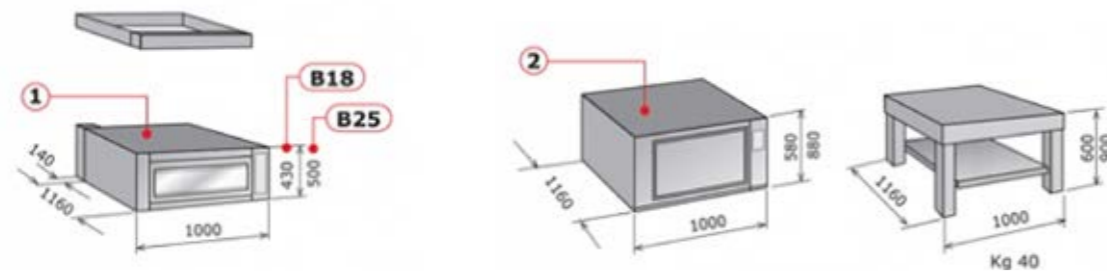

Dimensioni, specifiche tecniche, illustrazioni e descrizioni possono subire variazioni SENZA preavviso. / Dimensions, technical specifications, illustrations and descriptions CAN undergo variations without notice. / Les dimensions, les spécifications techniques, les illustrations et les descriptions sont sujets à changement SANS preavis. / الأبعاد ومواصفات الفنية والرسومات التوضيحية والأوصاف عرضة للتغيير دون إشعار.

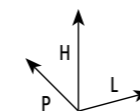

Dimensioni, specifiche tecniche, illustrazioni e descrizioni possono subire variazioni SENZA preavviso. / Dimensions, technical specifications, illustrations and descriptions CAN undergo variations without notice. / Les dimensions, les spécifications techniques, les illustrations et les descriptions sont sujets à changement SANS preavis. / الأبعاد ومواصفات الفنية والرسومات التوضيحية والأوصاف عرضة للتغيير دون إشعار.

MD/CO

MD/CT

MD/CP/1

CPS/1

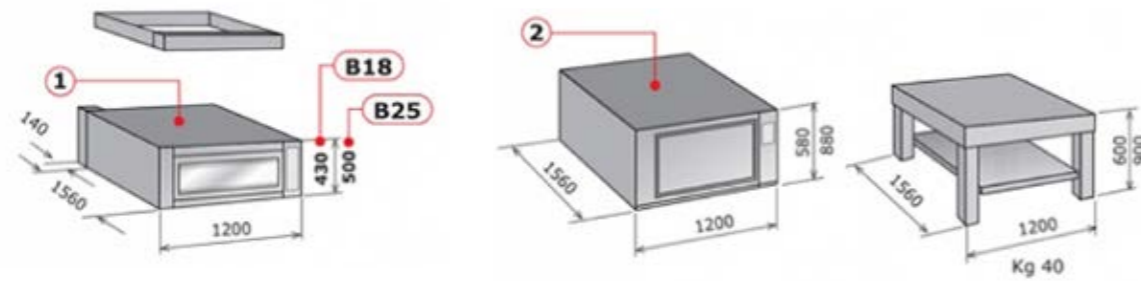

MODELLO MODEL MODELE النوع	N° CAMERE CHAMBRES حجرات	DIMENSIONI CAMERE CHAMBERS SIZE DIMENSIONS حجم الغرفة	DIMENSIONI ESTERNE OVERALL SIZE DIMENSIONS الابعاد الخارجية	MASSA WEIGHT POIDS كتلة	N° TEGLIE TRAY PLATEAUX صينية	N° PIZZE Ø 30 CM	DIMENSIONI TEGLIE TRAY SIZES TAILLE DES PLATEAUX أحجام الصواني	POTENZA POWER PUISSANCE قوة كو	PARZIALIZZATORE POWER DIVIDER PARTIALISATEUR مقسم الطاقة	ALIMENTAZIONE CURRENT COURANTE تيار
		L X P X H = mm	L X P X H = mm	Kg			mm	KW	KW	V
MD/CO-B18	1	820 x 1300 x 180	1200 x 1560 + 140 x 430	230	4	6/7	600 x 400	8,4	4,2	400+N
MD/CO-B25	1	820 x 1300 x 250	1200 x 1560 + 140 x 500	230	4	6/7	600 x 400	8,4	4,2	400+N
CELLA DI LIEVITAZIONE LEAVENING CELL CELLULE DE LEVAGE خلية التخمر		-	1200 x 1560 x 580-880	120	15-24	-	600 x 400	1,6	-	230M

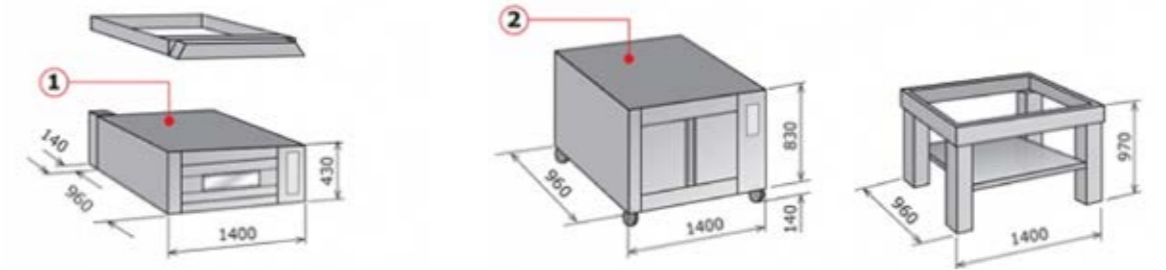

MODELLO MODEL MODELE النوع	N° CAMERE CHAMBRES حجرات	DIMENSIONI CAMERE CHAMBERS SIZE DIMENSIONS حجم الغرفة	DIMENSIONI ESTERNE OVERALL SIZE DIMENSIONS الابعاد الخارجية	MASSA WEIGHT POIDS كتلة	N° TEGLIE TRAY PLATEAUX صينية	N° PIZZE Ø 30 CM	DIMENSIONI TEGLIE TRAY SIZES TAILLE DES PLATEAUX أحجام الصواني	POTENZA POWER PUISSANCE قوة كو	PARZIALIZZATORE POWER DIVIDER PARTIALISATEUR مقسم الطاقة	ALIMENTAZIONE CURRENT COURANTE تيار
		L X P X H = mm	L X P X H = mm	Kg			mm	KW	KW	V
MD/CP/1	1	1020 x 700 x 180	1400 x 960 + 140 x 430	175	2	6	600 x 400	8,7	4,3	400+N
CELLA DI LIEVITAZIONE LEAVENING CELL CELLULE DE LEVAGE خلية التخمر		-	1400 x 960 x 830	120	28	-	600 x 400	1,6	-	230M

MODELLO MODEL MODELE النوع	N° CAMERE CHAMBRES حجرات	DIMENSIONI CAMERE CHAMBERS SIZE DIMENSIONS حجم الغرفة	DIMENSIONI ESTERNE OVERALL SIZE DIMENSIONS الابعاد الخارجية	MASSA WEIGHT POIDS كتلة	N° TEGLIE TRAY PLATEAUX صينية	N° PIZZE Ø 30 CM	DIMENSIONI TEGLIE TRAY SIZES TAILLE DES PLATEAUX أحجام الصواني	POTENZA POWER PUISSANCE قوة كو	PARZIALIZZATORE POWER DIVIDER PARTIALISATEUR مقسم الطاقة	ALIMENTAZIONE CURRENT COURANTE تيار
		L X P X H = mm	L X P X H = mm	Kg			mm	KW	KW	V
MD/CT-B18	1	820 x 1900 x 180	1200 x 2160 + 140 x 430	410	6	9	600 x 400	13,2	6,6	400+N
MD/CT-B25	1	820 x 1900 x 250	1200 x 2160 + 140 x 500	410	6	9	600 x 400	13,2	6,6	400+N
CELLA DI LIEVITAZIONE LEAVENING CELL CELLULE DE LEVAGE خلية التخمر		-	1200 x 1960 x 580-880	230	40-64	-	600 x 400	1,6	-	230M

MODELLO MODEL MODELE النوع	N° CAMERE CHAMBRES حجرات	DIMENSIONI CAMERE CHAMBERS SIZE DIMENSIONS حجم الغرفة	DIMENSIONI ESTERNE OVERALL SIZE DIMENSIONS الابعاد الخارجية	MASSA WEIGHT POIDS كتلة	N° TEGLIE TRAY PLATEAUX صينية	N° PIZZE Ø 30 CM	DIMENSIONI TEGLIE TRAY SIZES TAILLE DES PLATEAUX أحجام الصواني	POTENZA POWER PUISSANCE قوة كو	PARZIALIZZATORE POWER DIVIDER PARTIALISATEUR مقسم الطاقة	ALIMENTAZIONE CURRENT COURANTE تيار
		L X P X H = mm	L X P X H = mm	Kg			mm	KW	KW	V
CPS/1	1	1020 x 1020 x 180	1400 x 1320 + 140 x 430	175	4	9	600 x 400	10,5	5,3	400+N
CELLA DI LIEVITAZIONE LEAVENING CELL CELLULE DE LEVAGE خلية التخمر		-	1400 x 1320 x 830	120	28	-	600 x 400	1,6	-	230M

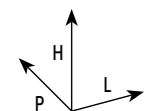
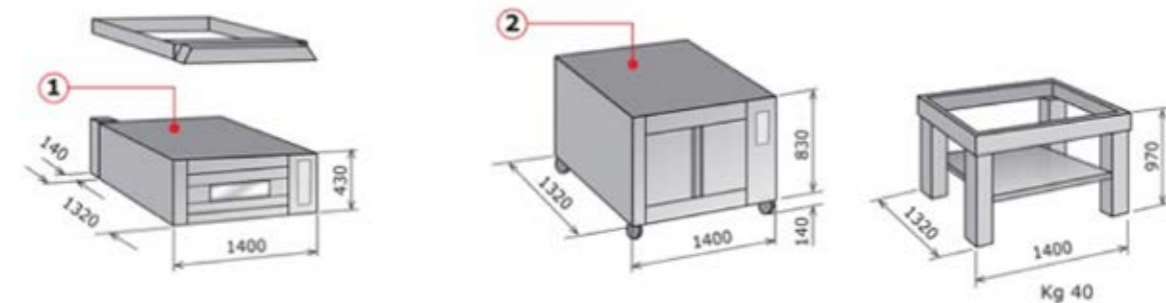
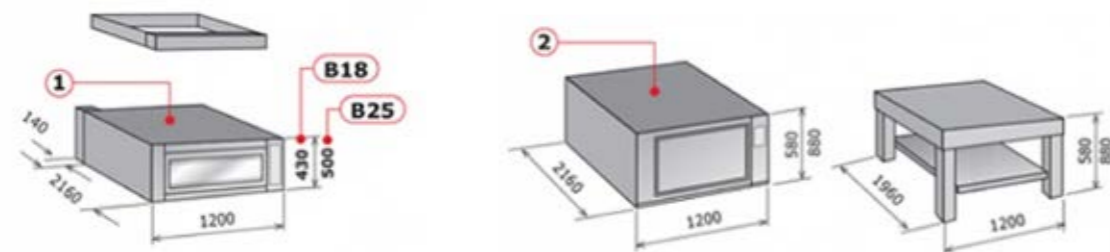

Dimensioni, specifiche tecniche, illustrazioni e descrizioni possono subire variazioni SENZA preavviso. / Dimensions, technical specifications, illustrations and descriptions CAN undergo variations without notice. / Les dimensions, les spécifications techniques, les illustrations et les descriptions sont sujets à changement SANS preavis. / الأبعاد والمواصفات الفنية والرسومات التوضيحية والأوصاف عرضة للتغيير دون إشعار.

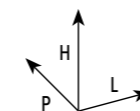

Dimensioni, specifiche tecniche, illustrazioni e descrizioni possono subire variazioni SENZA preavviso. / Dimensions, technical specifications, illustrations and descriptions CAN undergo variations without notice. / Les dimensions, les spécifications techniques, les illustrations et les descriptions sont sujets à changement SANS preavis. / الأبعاد والمواصفات الفنية والرسومات التوضيحية والأوصاف عرضة للتغيير دون إشعار.

MD/CN/R RAPIDO 2 CPR BICAMERA

MD/CN MD/CS

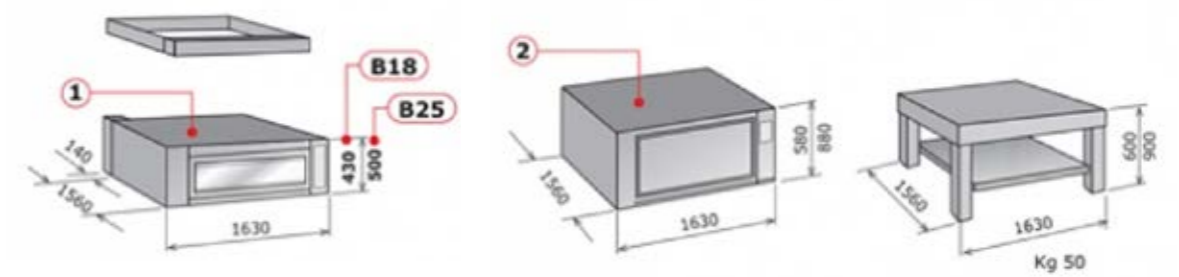
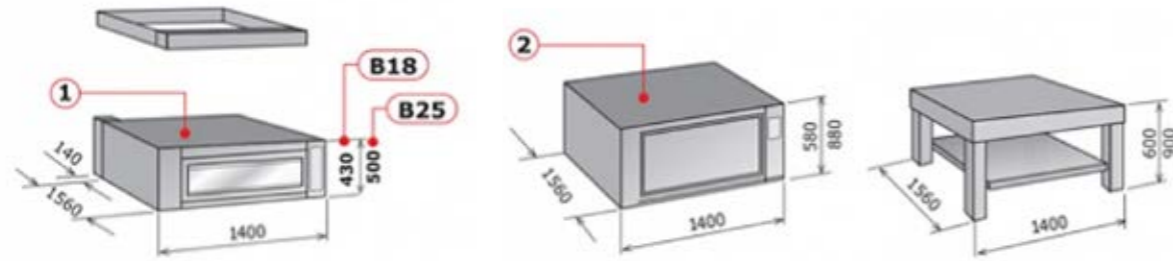

MODELLO MODEL MODÈLE النوع	N° CAMERE CHAMBRES غرف	DIMENSIONI CAMERE CHAMBERS SIZE DIMENSIONS CHAMBRES حجم الغرفة	DIMENSIONI ESTERNE OVERALL SIZE DIMENSIONS EXTÉRIEURES الأبعاد الخارجية	MASSA WEIGHT POIDS كتلة	N° TEGLIE TRAY PLATEAUX صينية	N° PIZZE Ø 30 CM	DIMENSIONI TEGLIE TRAY SIZES TAILLE DES PLATEAUX أحجام الصواني	POTENZA POWER PUISSANCE قوة كو	PARZIALIZZATORE POWER DIVIDER PARTIALISATEUR مقسم الطاقة	ALIMENTAZIONE CURRENT COURANTE تيار
		L X P X H = mm	L X P X H = mm	Kg			mm	KW	KW	V
MD/CN/R-B18	1	1020 x 1300 x 180	1400 x 1560 + 140 x 430	340	4	9	500 x 600	15	7,5	400+N
MD/CN/R-B25	1	1020 x 1300 x 250	1400 x 1560 + 140 x 500	340	4	9	500 x 600	15	7,5	400+N
CELLA DI LIEVITAZIONE LEAVENING CELL CELLULE DE LEVAGE خلية التخمر		-	1400 x 1560 x 580-880	200	30-48	-	600 x 400	1,6	-	230M

MODELLO MODEL MODÈLE النوع	N° CAMERE CHAMBRES غرف	DIMENSIONI CAMERE CHAMBERS SIZE DIMENSIONS CHAMBRES حجم الغرفة	DIMENSIONI ESTERNE OVERALL SIZE DIMENSIONS EXTÉRIEURES الأبعاد الخارجية	MASSA WEIGHT POIDS كتلة	N° TEGLIE TRAY PLATEAUX صينية	N° PIZZE Ø 30 CM	DIMENSIONI TEGLIE TRAY SIZES TAILLE DES PLATEAUX أحجام الصواني	POTENZA POWER PUISSANCE قوة كو	PARZIALIZZATORE POWER DIVIDER PARTIALISATEUR مقسم الطاقة	ALIMENTAZIONE CURRENT COURANTE تيار
		L X P X H = mm	L X P X H = mm	Kg			mm	KW	KW	V
MD/CN-B18	1	1250 x 1300 x 180	1630 x 1560 + 140 x 430	340	6	10	600 x 400	15	7,5	400+N
MD/CN-B25	1	1250 x 1300 x 250	1630 x 1560 + 140 x 500	340	6	10	600 x 400	15	7,5	400+N
CELLA DI LIEVITAZIONE LEAVENING CELL CELLULE DE LEVAGE خلية التخمر		-	1630 x 1560 x 580-880	200	30-48	-	600 x 400	1,6	-	230M

MODELLO MODEL MODÈLE النوع	N° CAMERE CHAMBRES غرف	DIMENSIONI CAMERE CHAMBERS SIZE DIMENSIONS CHAMBRES حجم الغرفة	DIMENSIONI ESTERNE OVERALL SIZE DIMENSIONS EXTÉRIEURES الأبعاد الخارجية	MASSA WEIGHT POIDS كتلة	N° TEGLIE TRAY PLATEAUX صينية	N° PIZZE Ø 30 CM	DIMENSIONI TEGLIE TRAY SIZES TAILLE DES PLATEAUX أحجام الصواني	POTENZA POWER PUISSANCE قوة كو	PARZIALIZZATORE POWER DIVIDER PARTIALISATEUR مقسم الطاقة	ALIMENTAZIONE CURRENT COURANTE تيار
		L X P X H = mm	L X P X H = mm	Kg			mm	KW	KW	V
RAPIDO 2 CPR BICAMERA	2	620 x 650 x 180 + 180	920 x 910 + 140 x 650	150	1+1	4+4	600 x 600	13,2	6,6	400+N
CELLA DI LIEVITAZIONE LEAVENING CELL CELLULE DE LEVAGE خلية التخمر		-	920 x 910 x 1000	85	16	-	600 x 400	1,6	-	230M

MODELLO MODEL MODÈLE النوع	N° CAMERE CHAMBRES غرف	DIMENSIONI CAMERE CHAMBERS SIZE DIMENSIONS CHAMBRES حجم الغرفة	DIMENSIONI ESTERNE OVERALL SIZE DIMENSIONS EXTÉRIEURES الأبعاد الخارجية	MASSA WEIGHT POIDS كتلة	N° TEGLIE TRAY PLATEAUX صينية	N° PIZZE Ø 30 CM	DIMENSIONI TEGLIE TRAY SIZES TAILLE DES PLATEAUX أحجام الصواني	POTENZA POWER PUISSANCE قوة كو	PARZIALIZZATORE POWER DIVIDER PARTIALISATEUR مقسم الطاقة	ALIMENTAZIONE CURRENT COURANTE تيار
		L X P X H = mm	L X P X H = mm	Kg			mm	KW	KW	V
MD/CS-B18	1	1250 x 1700 x 180	1630 x 1960 + 140 x 430	410	8	14	600 x 400	15	7,5	400+N
MD/CS-B25	1	1250 x 1700 x 250	1630 x 1960 + 140 x 500	410	8	14	600 x 400	15	7,5	400+N
CELLA DI LIEVITAZIONE LEAVENING CELL CELLULE DE LEVAGE خلية التخمر		-	1630 x 1960 x 580-880	120	-	-	600 x 400	1,6	-	230M

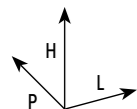
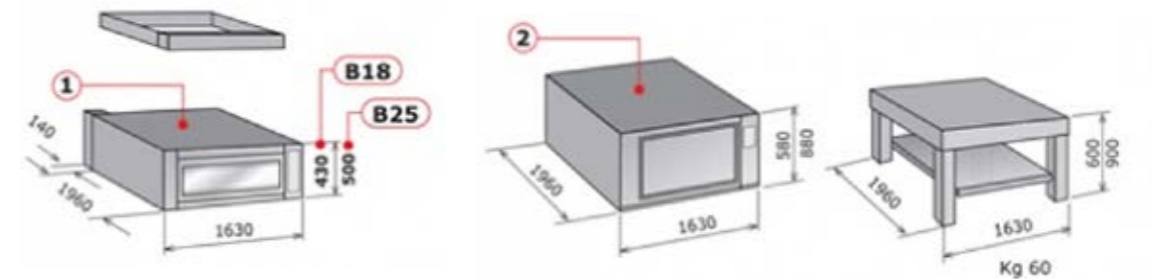
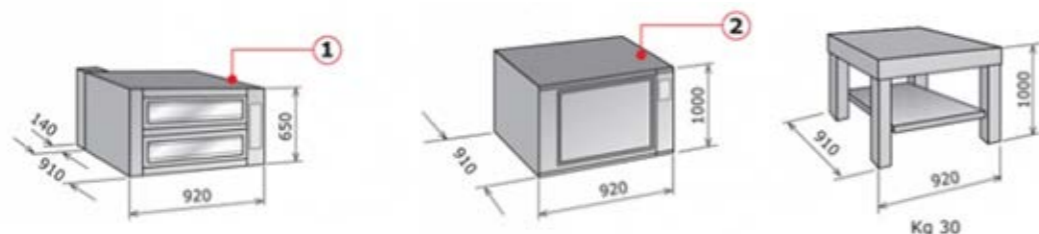

Dimensioni, specifiche tecniche, illustrazioni e descrizioni possono subire variazioni SENZA preavviso. / Dimensions, technical specifications, illustrations and descriptions CAN undergo variations without notice. / Les dimensions, les spécifications techniques, les illustrations et les descriptions sont sujets à changement SANS préavis. / الأبعاد والمواصفات الفنية والرسومات التوضيحية والأوصاف عرضة للتغيير دون إشعار.

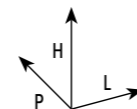

Dimensioni, specifiche tecniche, illustrazioni e descrizioni possono subire variazioni SENZA preavviso. / Dimensions, technical specifications, illustrations and descriptions CAN undergo variations without notice. / Les dimensions, les spécifications techniques, les illustrations et les descriptions sont sujets à changement SANS préavis. / الأبعاد والمواصفات الفنية والرسومات التوضيحية والأوصاف عرضة للتغيير دون إشعار.

SUPER RAPIDO CPD BICAMERA MD/CP BICAMERA

CPS BICAMERA MD/CH

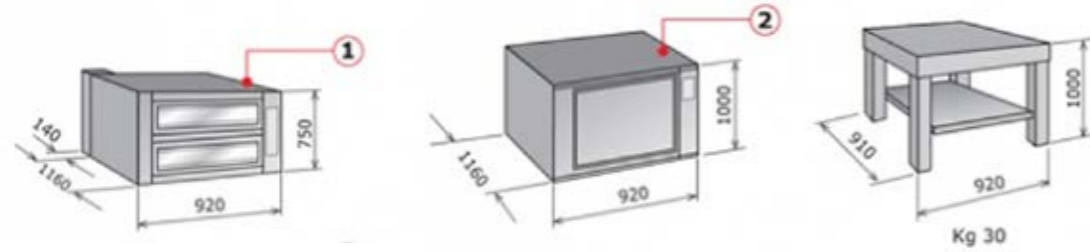

MODELLO MODEL MODÈLE النوع	N° CAMERE CHAMBRES غرف	DIMENSIONI CAMERE CHAMBERS SIZE DIMENSIONS CHAMBRES حجم الغرفة	DIMENSIONI ESTERNE OVERALL SIZE DIMENSIONS EXTÉRIEURES الأبعاد الخارجية	MASSA WEIGHT POIDS كتلة	N° TEGLIE TRAY PLATEAUX صينية	N° PIZZE Ø 30 CM	DIMENSIONI TEGLIE TRAY SIZES TAILLE DES PLATEAUX أحجام الصواني	POTENZA POWER PUISSANCE قوة كو	PARZIALIZZATORE POWER DIVIDER PARTIALISATEUR مقسم الطاقة	ALIMENTAZIONE CURRENT COURANTE تيار
		L X P X H = mm	L X P X H = mm	Kg			mm	KW	KW	V
SUPER RAPIDO CPD BICAMERA	2	620 x 900 x 180 + 180	920 x 1160 + 140 x 750	220	2 + 2	6 + 6	600 x 400	12	-	400+N
CELLA DI LIEVITAZIONE LEAVENING CELL CELLULE DE LEVAGE خلية التخمر	-	-	920 x 1160 x 1000	95	16	-	600 x 400	1,6	-	230M

MODELLO MODEL MODÈLE النوع	N° CAMERE CHAMBRES غرف	DIMENSIONI CAMERE CHAMBERS SIZE DIMENSIONS CHAMBRES حجم الغرفة	DIMENSIONI ESTERNE OVERALL SIZE DIMENSIONS EXTÉRIEURES الأبعاد الخارجية	MASSA WEIGHT POIDS كتلة	N° TEGLIE TRAY PLATEAUX صينية	N° PIZZE Ø 30 CM	DIMENSIONI TEGLIE TRAY SIZES TAILLE DES PLATEAUX أحجام الصواني	POTENZA POWER PUISSANCE قوة كو	PARZIALIZZATORE POWER DIVIDER PARTIALISATEUR مقسم الطاقة	ALIMENTAZIONE CURRENT COURANTE تيار
		L X P X H = mm	L X P X H = mm	Kg			mm	KW	KW	V
MD/CP BICAMERA	2	1020 x 700 x 180 + 180	1400 x 960 + 140 x 750	360	4 + 4	6 + 6	600 x 400	17,4	8,7	400+N
CELLA DI LIEVITAZIONE LEAVENING CELL CELLULE DE LEVAGE خلية التخمر	-	-	1400 x 960 x 830	120	28	-	600 x 400	1,6	-	230M

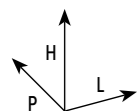
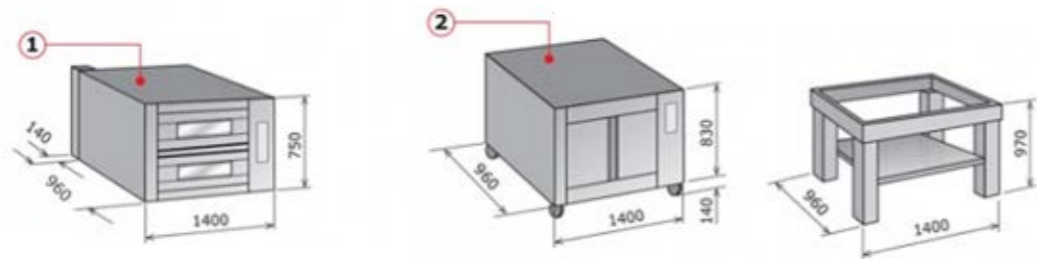

Dimensioni, specifiche tecniche, illustrazioni e descrizioni possono subire variazioni SENZA preavviso. / Dimensions, technical specifications, illustrations and descriptions CAN undergo variations without notice. / Les dimensions, les spécifications techniques, les illustrations et les descriptions sont sujets à changement SANS préavis. / الأبعاد والمواصفات الفنية والرسومات التوضيحية والأوصاف عرضة للتغيير دون إشعار.

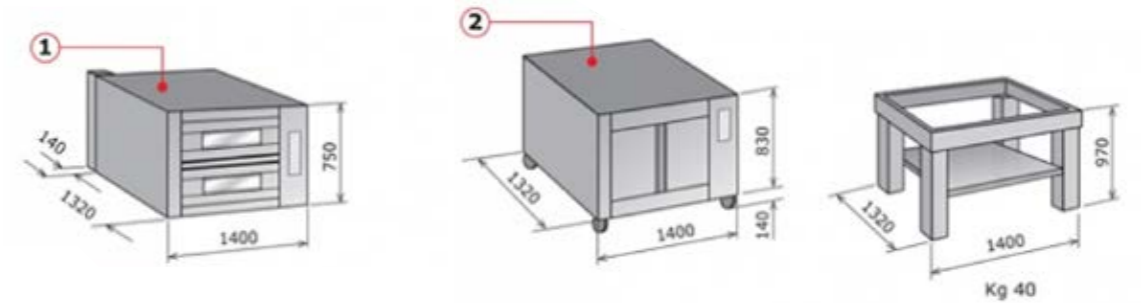

MODELLO MODEL MODÈLE النوع	N° CAMERE CHAMBRES غرف	DIMENSIONI CAMERE CHAMBERS SIZE DIMENSIONS CHAMBRES حجم الغرفة	DIMENSIONI ESTERNE OVERALL SIZE DIMENSIONS EXTÉRIEURES الأبعاد الخارجية	MASSA WEIGHT POIDS كتلة	N° TEGLIE TRAY PLATEAUX صينية	N° PIZZE Ø 30 CM	DIMENSIONI TEGLIE TRAY SIZES TAILLE DES PLATEAUX أحجام الصواني	POTENZA POWER PUISSANCE قوة كو	PARZIALIZZATORE POWER DIVIDER PARTIALISATEUR مقسم الطاقة	ALIMENTAZIONE CURRENT COURANTE تيار
		L X P X H = mm	L X P X H = mm	Kg			mm	KW	KW	V
CPS BICAMERA	2	1020 x 700 x 180 + 180	1400 x 1320 + 140 x 750	360	4 + 4	9 + 9	600 x 400	21	10,5	400+N
CELLA DI LIEVITAZIONE LEAVENING CELL CELLULE DE LEVAGE خلية التخمر	-	-	1400 x 1320 x 830 + 140	120	28	-	600 x 400	1,6	-	230M

MODELLO MODEL MODÈLE النوع	N° CAMERE CHAMBRES غرف	DIMENSIONI CAMERE CHAMBERS SIZE DIMENSIONS CHAMBRES حجم الغرفة	DIMENSIONI ESTERNE OVERALL SIZE DIMENSIONS EXTÉRIEURES الأبعاد الخارجية	MASSA WEIGHT POIDS كتلة	N° TEGLIE TRAY PLATEAUX صينية	N° PIZZE Ø 30 CM	DIMENSIONI TEGLIE TRAY SIZES TAILLE DES PLATEAUX أحجام الصواني	POTENZA POWER PUISSANCE قوة كو	PARZIALIZZATORE POWER DIVIDER PARTIALISATEUR مقسم الطاقة	ALIMENTAZIONE CURRENT COURANTE تيار
		L X P X H = mm	L X P X H = mm	Kg			mm	KW	KW	V
MD/CH-B18	1	1250 x 700 x 180	1630 x 960 + 140 x 430	220	3	5	600 x 400	6,4	4,2	400+N
MD/CH-B25	1	1250 x 700 x 250	1630 x 960 + 140 x 500	220	3	5	600 x 400	6,4	4,2	400+N
CELLA DI LIEVITAZIONE LEAVENING CELL CELLULE DE LEVAGE خلية التخمر	-	-	1630 x 960 x 580-880	120	20-32	-	600 x 400	1,6	-	230M

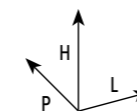
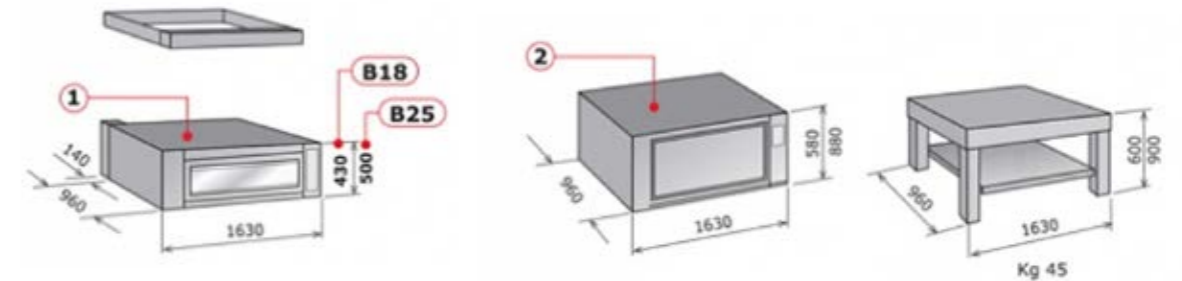

Dimensioni, specifiche tecniche, illustrazioni e descrizioni possono subire variazioni SENZA preavviso. / Dimensions, technical specifications, illustrations and descriptions CAN undergo variations without notice. / Les dimensions, les spécifications techniques, les illustrations et les descriptions sont sujets à changement SANS préavis. / الأبعاد والمواصفات الفنية والرسومات التوضيحية والأوصاف عرضة للتغيير دون إشعار.

OPTIONAL
OPTIONAL
OPTION
خيارات

I APP CLOUD EPOCA

per connettere in remoto il forno tramite Wi-Fi.

- Utilizzo semplificato e intuitivo grazie al display user-friendly
- Gestione duale della temperatura che permette di regolare separatamente le temperature di cielo e platea per adattarsi a differenti cotture per qualsiasi ricetta
- Con il Cloud EPoCA è possibile scaricare in input ed output dati, visualizzare grafici e preimpostare fino a 49 programmi di cottura.

GB EPOCA CLOUD APP

to remotely connect the oven via Wi-Fi.

- Simplified and intuitive use thanks to the user-friendly display
- Dual temperature management that allows you to adjust the top and bottom temperatures separately to adapt to different cooking methods for any recipe
- With the Cloud EPoCA it is possible to download input and output data, view graphs and preset up to 49 cooking programs.

F APPLICATION EPOCA CLOUD

pour connecter le four à distance via Wi-Fi.

- Utilisation simplifiée et intuitive grâce à l'affichage convivial
- Double gestion de la température qui vous permet d'ajuster les températures supérieure et inférieure séparément pour s'adapter aux différentes méthodes de cuisson pour n'importe quelle recette.
- Avec le Cloud EPoCA, il est possible de télécharger des données d'entrée et de sortie, de visualiser des graphiques et de pré-régler jusqu'à 49 programmes de cuisson.

- SA** تطبيق سحابة EPOCA لتوصيل الفرن عن بعد عبر Wi-Fi.
- استخدام مبسط وبديهي بفضل الشاشة سهلة الاستخدام
 - إدارة درجة الحرارة المزدوجة التي تسمح لك بضبط درجات الحرارة العلوية والسفلية بشكل منفصل للتكيف مع طرق الطهي المختلفة لأي وصفة
 - باستخدام Cloud EPoCA ، يمكن تنزيل بيانات الإدخال والإخراج وعرض الرسوم البيانية وأعداد ما يصل إلى 49 برنامجا للطهي مسبقا.



EV8318

pannello con tasti capacitivi 2,8"
panel with 2.8" capacitive keys
panneau avec touches capacitives de 2,8"
لوحة بمفاتيح سعوية 2.8 بوصة

Vcolor 378

display touch screen 5"
5" touch screen display
Écran tactile 5"
شاشة تعمل باللمس مقاس 5 بوصات





ilem
BAKERY

Viale del Lavoro, 30
37030 Colognola ai Colli
Verona - Italy

Tel. +39 045 6152139

info@ilembakery.com

www.ilembakery.com